

# DE·X

Refrigeration Dryers

Nominal air-flow 0,35 – 34,6 m<sup>3</sup>/min.



*Purifying your compressed air,  
increasing your efficiency.*



Cooling, conditioning, purifying.

# DE-X | The fail-safe industrial solution

## Quality, performance and reduced carbon footprint

DRY ENERGY® DE-X dryers offer accurate dew point control in an easy-to-use package with very wide operating parameters and a strong focus on reducing overall global impacts.

Unique features and **patented technologies** ensure the requirements of **individual industrial applications** are fully catered for.



### Optimum operation in all conditions

DE-X offers high operating limits: 70 °C air inlet (DE-X 090-350 = 65 °C), 50 °C ambient (DE-X 290 = 48°C, DE-X 350 = 46 °C) and 16barg maximum pressure (DE-X 180-350 = 14barg). The unit automatically and continuously adjusts operation to all conditions.

### Peace of mind

A robust construction with field-proven technologies, premium quality components, a full specification and extensive factory testing ensures high reliability and guaranteed operation.

### Easy to install

DE-X is supplied pre-programmed with no need for adjustments. A single cabled electrical connection is provided, with a Schuko plug on DE-X 003-140. A compressed air by-pass kit is available on request.

### Easy to use

DE-X is compact, with easily removable panels and simple frontal access to all components. Automatic restart is standard on all models. Only minimum maintenance is required, with the LLF function simplifying seasonal adjustment needs.

### Xtraordinary DE-X: the benefits

- ▶ **Reduced energy consumptions**  
Market leading pressure drops (average < 0,12 bar)
- ▶ **Environmentally friendly**  
Refrigerant R513A on DE-X 003-090, offering a 70% GWP reduction
- ▶ **Always operates**  
Air inlet up to 70°C, ambient up to 50°C
- ▶ **High reliability**  
Field proven technology, premium components
- ▶ **Unique X-MODULE exchanger**  
Patented 3-in-1 exchanger, designed by MTA
- ▶ **Easy to use**  
Intuitive controller, avoids field adjustments, low maintenance

### X-MODULE

#### The innovative patented heat exchanger

- Market leading pressure drops (average < 0,12 bar)
- Compact and robust all-aluminium 3-in-1 configuration
- Optimum dew point control with large separation section
- Generous air-to-air exchanger reduces energy consumptions

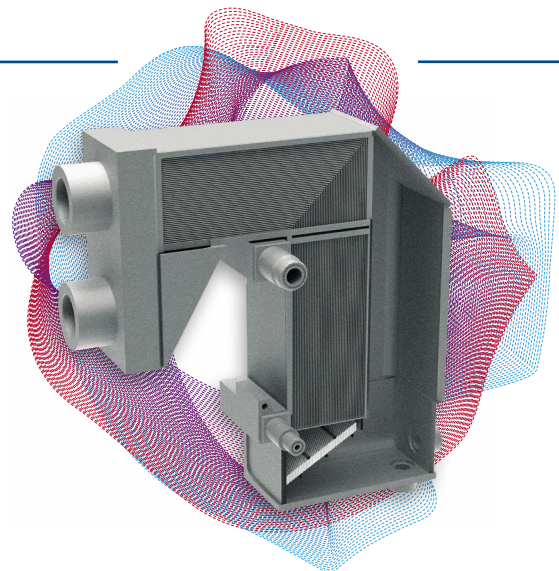

## Advanced iDRY microprocessor

The multi-icon microprocessor features a digital dew point reading, text messages, multiple alarms including a user alarm, maintenance scheduling and extensive programming via multi-level menus.

An alarm history and USB programming port are standard.



## Easy Connectivity

DE-X features a volt-free general alarm signal, a user alarm connection and either remote dryer on-off control or RS485 serial Modbus interfacing (via an optional Gateway); the dryer is Industry 4.0 ready.

## Accurate dewpoint control

DE-X's hot gas by-pass valve continuously and rapidly maintains stable dewpoints in all conditions. Cycling dryers without a thermal mass, and variable speed dryers which cannot accurately adjust operation at low loads, risk dewpoint instabilities.

## Quality specifications

Reciprocating (DE-X 003-090), rotary (DE-X 120-140) and scroll (DE-X 180-350) compressors are applied, with phase monitors from DE-X 180. DE-X 180-350 feature a thermostatic expansion valve, an HP switch is mounted from DE-X 018. A corrosion resistant condenser coating is standard on DE-X 003-027 and optional from DE-X 032, with an easily cleanable condenser pre-filter mounted from DE-X 180. Water-cooled versions are available from DE-X 015.

## Condensate drains

Three differing configurations are available: CDE electronic zero-loss drains with a visual alarm (DE-X 180-350 also feature a remote alarm contact and digital condensate level indication); CDS Smart electronic zero-loss drains (available on DE-X 003-060); iDRAIN, a timed drain which automatically, and without programming, adapts its operation at low loads, notably improving its energy efficiency. All drain configurations offer a protective filter, shut-off valve and test button. iDRAIN is programmed via the microprocessor.

## Ecological refrigerant

DE-X 003-090 feature refrigerant R513A, with a GWP of 573 which is 70% lower than typically applied refrigerants. This offers a future proof solution with reduced carbon footprints.

## Low Load Function (LLF)

LLF automatically cycles operation at zero load, protecting against dryer freezing and simplifying seasonal adjustment needs. LLF also offers stand-by energy savings when ambient temperatures are low enough.

- ① Microprocessor control
- ② Electrical panel
- ③ Condenser
- ④ Compressor
- ⑤ 3-in-1 exchanger
- ⑥ Condensate drain



## Significant energy savings

### Pressure drops make a difference

Nearly 30% of a dryer's total lifecycle costs are due to the energy required to overcome its pressure drop.

DE-X's market leading pressure drops are on average less than 0,12 bar, typical dryers can be double this.

For a DE-X 120, a 0,1bar pressure drop reduction results in a 1.819 kWh/year energy decrease, equivalent to an annual saving of €434 (at energy cost €0,24 per kWh).

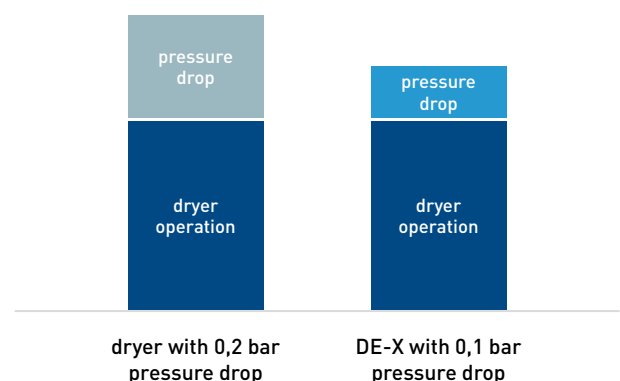

Model	Nominal air flow				Nominal absorbed power kW	Overall dimensions (mm)			Weight (kg)	Air connections (Rp)
	CLASS 4 dew point ≤ 3 °C		CLASS 5 dew point ≤ 7 °C			A (width)	B (depth)	C (height)		
	m³/min	m³/h	m³/min	m³/h						
DE-XG 003	0,35	21	0,43	26	0,11	390	407	400	21	1/2"
DE-XG 005	0,5	30	0,6	37	0,15	390	407	400	21	1/2"
DE-XG 007	0,65	39	0,8	48	0,18	390	407	400	21	1/2"
DE-XG 010	0,95	57	1,15	69	0,23	390	407	400	23	1/2"
DE-XG 012	1,2	72	1,5	88	0,3	390	407	400	24	1/2"
DE-XG 015	1,5	90	1,8	108	0,35	380	497	661	36	3/4"
DE-XG 018	1,8	108	2,2	131	0,41	380	497	661	41	3/4"
DE-XG 022	2,2	132	2,7	161	0,46	380	497	661	42	3/4"
DE-XG 027	2,7	162	3,2	195	0,58	380	497	661	45	1"
DE-XG 032	3,2	192	3,8	229	0,81	720	536	856	54	1"
DE-XG 040	4,0	241	4,8	290	0,82	720	518	856	56	1"
DE-XG 045	4,5	270	5,4	325	1,01	720	518	856	68	1"
DE-XG 060	6,0	361	7,2	429	1,1	720	518	856	71	1 1/2"
DE-XG 070	7,0	420	8,3	498	1,13	720	518	856	75	1 1/2"
DE-XG 090	9,0	541	10,6	638	1,35	885	703	1086	110	1 1/2"
DE-XK 120	12,0	720	14,2	853	1,21	885	710	1086	115	2"
DE-XK 140	14,0	840	16,5	990	1,67	885	710	1086	115	2"
DE-XK 180	17,5	1050	20,8	1245	1,69	1000	963	1200	192	2 1/2"
DE-XK 200	20,0	1202	23,7	1423	2,07	1000	963	1200	194	2 1/2"
DE-XK 240	24,0	1441	28,4	1705	2,56	1000	963	1200	205	2 1/2"
DE-XK 290	28,5	1712	33,7	2020	3,02	1000	963	1200	220	3"
DE-XK 350	34,6	2075	40,6	2437	4,15	1000	963	1200	224	3"

Data refers to the following working conditions: air FAD 20 °C / 1bar A, pressure 7 bar(g), ambient temperature 25 °C, air inlet temperature 35 °C, according to ISO 8573.1 standard. Weights are net (without packing and for timed drain configuration). Refrigerant fluids: R513A (DE-X 003-090), R410A (DE-X 120-350). Protection class IP22. Maximum working pressure 16 bar(g) (DE-X 003-140), 14 bar(g) (DE-X 180-350). Maximum ambient temperature 50 °C (DE-X 003-240), 48 °C (DE-X 290), 46 °C (DE-X 350). Maximum inlet temperature 70 °C (DE-X 003-070), 65 °C (DE-X 090-350). Power supply: 230V ±10% / 1Ph / 50Hz (DE-X 003-140); 400V ±10% / 3Ph / 50Hz (DE-X 180-350); special voltages available on request.

A pre-filter (minimum filtration grade P - 3 µm) must be installed to protect the dryer and improve air quality.

Timed drains are mounted internally; electronic zero-loss drains are mounted internally on DE-X 015-350, while on DE-X 003-012 they are packaged separately to be mounted externally using the supplied couplings.

The correction factors in the following table should be used as a guide only; for accurate selection at conditions differing from the above please contact MTA.

Capacity Correction Factors (indicative values): CAPACITY = RATED VALUE CLASS 4 at 7 bar(g) x K1 x K2 x K3 x K4.

Not all correction factors are applicable for all DE-X models, according to their maximum operating limits; refer to above details accordingly.

Working pressure	bar (g)	3	4	5	6	7	8	9	10	11	12	13	14	15	16	
Correction factor	K1	0,68	0,79	0,88	0,95	1,00	1,04	1,07	1,10	1,13	1,15	1,17	1,18	1,20	1,21	
Air inlet temperature	°C	30	35	40	45	50	55	60	65	70						
Correction factor	K2	1,19	1,00	0,82	0,66	0,55	0,48	0,48	0,48	0,48						
Pressure dew point	°C	3	4	5	6	7	8	9	10							
Correction factor	K3	1,00	1,05	1,10	1,15	1,20	1,25	1,30	1,37							
Ambient temperature	°C	20	25	30	35	40	45	50								
Correction factor	K4	1,04	1,00	0,95	0,90	0,84	0,78	0,72								

DE-XG 003 - 012

DE-XG 015 - 027

DE-XG 032 - 070

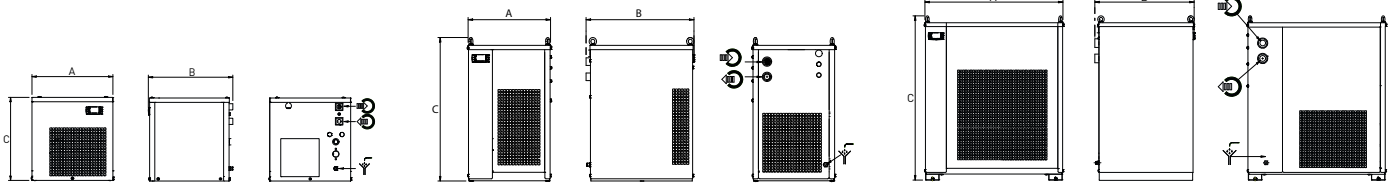

DE-XG 090 / DE-XK 120 - 140

DE-XK 180 - 350

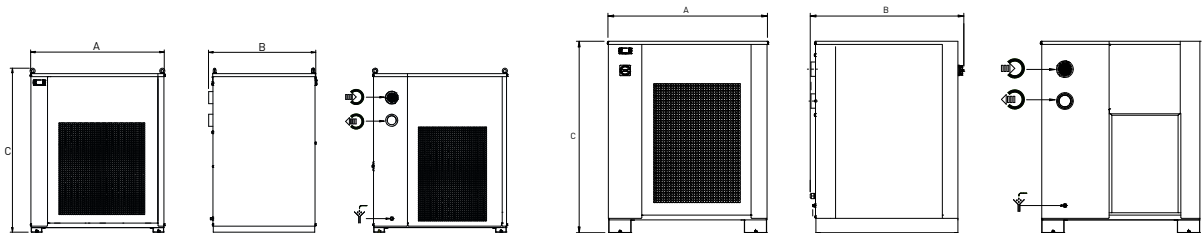

MTA is ISO9001 certified, a sign of its commitment to complete customer satisfaction.



MTA products comply with European safety directives, as recognised by the CE symbol.

**M.T.A. S.p.A.**  
 Business office  
 Viale Spagna, 8 ZI  
 35020 Tribano (PD) Italy  
 Tel. +39 049 9588611  
 info@mta-it.com  
 www.mta-it.com



Cooling, conditioning, purifying.